

Remote Fiber Test System (RFTS)

Proactive optical fiber infrastructure monitoring

Remote Fiber Test System (RFTS) monitors any type of optical fiber infrastructure, including core, metro, access, FTTx and PON networks. RFTS can operate as standalone device or as part of a centralized monitoring system.

Remotely managed OTDR instrument provides capability to continuously monitor and troubleshoot optical fibers from deployment to maintenance.

Proactive network testing, monitoring and rapid reaction are important to reduce Mean Time to Repair (MTTR).

RFTS consists of 3 main parts:

- RTU – base unit hosting MEMS optical switch and slots for modules
- OTDR module – Fiber Fault Reflectometer in SFP form factor
- Management module – Mini Server in SFP powered by full featured Linux OS

Management module provides reach capabilities to automate monitoring workflow and simplify integration – agent installation, API integration with third-party solutions.

Also, management module has an IP SLA features – Y.1564, Smart Loopback and TWAMP – to measure network performance and run Service Active Test (SAT).

Applications:

- Core, Metro, Access
- FTTx, PON
- CWDM
- DCI
- Light fiber (In-service)
- Dark fiber (Out-of-service)

Key features:

- 16 fibers
- Up to 40 km
- Management via copper, optical or cellular
- Automated fault location
- Standalone operation
- Alarming
- History
- Built-in IP SLA probe
- Cost-effective

```
rfts# show measurements
Port | Status | Distance
-----|-----|-----
1 | Alarm | 35874
2 | OK |
3 | OK |
4 | OK |
5 | Alarm | 1250
6 | OK |
7 | Alarm | 29633
8 | OK |
...
```

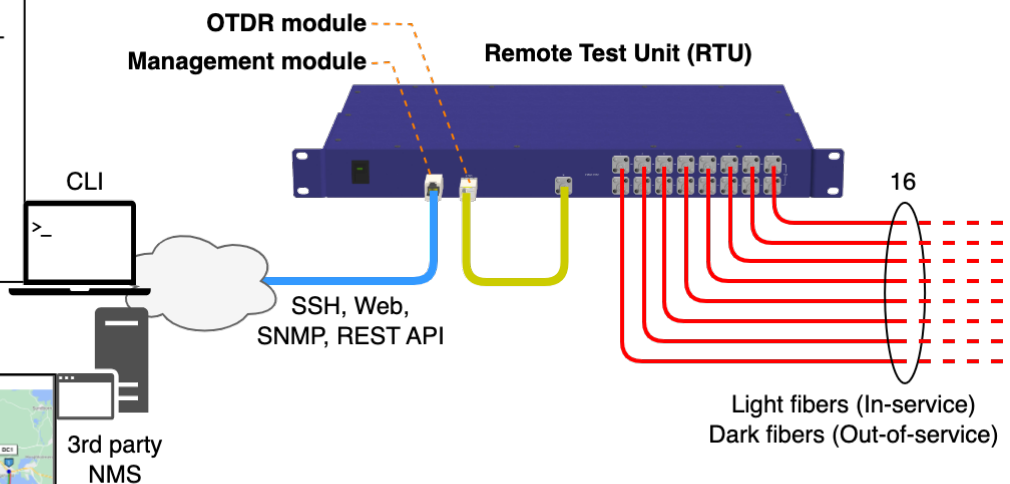
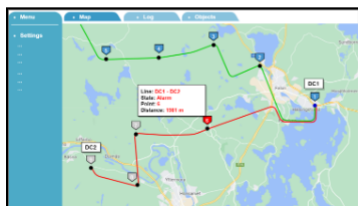



Fiber monitoring:

- 16 fibers
- Up to 40 km
- Wavelength: any CWDM, 1625, 1650 nm
- OTDR optical budget 56 dBm
- SC, FC or LC connector
- APC or UPC
- Auto/scheduled testing
- On demand testing
- Robust MEMS optical switch

IP SLA:

- Y.1564: line rate, 4 streams, 1-way, 2-way
- Smart Loopback L2-L4
- TWAMP Light

Management:

- Standalone operation
- OSS integration
- Connectivity via:
 - Ethernet, copper, RJ-45
 - Ethernet, fiber optic, up to 20 km, LC
 - Cellular 3G/4G (with external modem)
- CLI over SSH, Web, SNMP, REST API
- Static IP, DHCP
- IPv4, IPv6, VRF
- VLAN
- ACL, VPN
- NTP client, PTP slave
- Alarming: SNMP, Syslog, Email, Messengers
- History, Local storage
- Remote software upgrade

General:

- Modular design:
 - Management module
 - OTDR module
- 1 RU
- AC or DC
- Fanless

Ordering information

Remote Test Unit (RTU):

Remote Test Unit (RTU), SFP slot for management module, SFP slot for OTDR module, MEMS optical switch 1x16, SC/APC, 1RU, AC or DC

OTDR module:

Intelligent SFP module, Gigabit Ethernet, STM-1/4, Fiber Fault Reflectometer, I2C management, 1000BASE-EX, DDM, Tx: 1550 nm, Rx: 1550 nm, 40 km, SMF, LC/UPC

Optionally – any CWDM, 1625, 1650 nm wavelength

Management modules:

Intelligent SFP module, ARM CPU, FPGA, Gigabit Ethernet, 1000BASE-LX, DDM, 1310 nm, 20 km, 2xSMF, LC

Intelligent SFP module, ARM CPU, FPGA, Gigabit Ethernet, 1000BASE-LX, DDM, Tx: 1310 nm, Rx: 1550 nm, 20 km, SMF, LC

Intelligent SFP module, ARM CPU, FPGA, Gigabit Ethernet, 1000BASE-LX, DDM, Tx: 1550 nm, Rx: 1310 nm, 20 km, SMF, LC

Intelligent SFP module, ARM CPU, FPGA, Gigabit Ethernet, 10/100/1000BASE-T, RJ-45

Intelligent SFP module, ARM CPU, FPGA, Gigabit Ethernet, USB, Type A

IP SLA feature set (optional):

Loaned IP, PTP, Smart Loopback, Y.1564

Find out more: plumspace.com, info@plumspace.com

We are open for partnership